

# Essential factors influencing cathodic protection not covered by standards and recommended practices

Paper no 1022

Harald Osvoll,

*FORCE Technology Norway AS,*

*Norway*

## 1 Background

Cathodic protection calculations for both offshore and onshore is based on standards and Recommended practices. These guidelines and recommendations do not fully cover special cases as e.g. anode interference, significant shadow effects, limited space and crevices and protection within annuluses and tubing. In addition, it is recognised that there are different approaches related to attenuation calculation of pipelines. This paper will evaluate these important special problems and summarize some deviations between the different standards and recommended practices./1-7/.

## 2 Introduction

When performing a detailed CP design it is required to follow a set of defined design rules to secure a safe system. There are several official design specifications and recommended practices both national and international. These different design basis documents have been used over many years and are continuously developed over many years. The institutions behind the different design guideline documents are as follows:

- NACE
- ISO
- DnV
- NORSOK
- EN

The most important guideline documents are:

- NACE SP0176 (former RP0176) – for offshore structures
- DnV RP B401 – for offshore structures
- DnV RP B101 – for floating structures
- DnV RP F103 – for offshore pipelines
- ISO 15589-2 – for offshore pipelines
- EN 12474 – for offshore pipelines
- EN 12495 – for platform structures
- NORSOK M-503 - for offshore structures

The above standards do typical give recommendations on the following:

- Current densities
- Coating breakdown figures
- Which parts to include
- Safety factors
- Resistivity data
- Calculations procedures
- Anode resistance formulas
- Driving voltage
- Anode alloy, composition, capacity and test methods
- Requirements for electrical continuity
- Parts/components/structures draining current as
  - e.g. piles and wells in mud
  - Anchoring chains
- Attenuation calculation of pipelines

The detail level in the different standards differs and also the way the standards are defining the design rules whether they shall be strictly followed or just regarded as recommendations or guiding.

In the different documents there several elements, which are not well covered. Among several aspects in terms of cathodic protection the following is not well defined, not clearly described or actual background/reason not given:

- The “rule of thumb” of a maximum protection length or drain length in order of 5 \* internal diameter well
- Internal protection in general as e.g. caissons, chain connectors, etc.
- Anode interference effects
- Shadow effects
- Uneven anode distribution
- Current drain to well casings
- Current drain to anchor chains (not covered in this paper – see /13/)
- Remote protection – attenuation calculations for pipelines
- Current drain to steel in mud especially related to what length of piles in mud to include in drain calculations.
- Current drain to anchor chains (not covered in this paper, see paper /13/)
- Over protection potential limits due to risk for cathodic disbonding and/or hydrogen embrittlement (not covered in this paper)

- Size of electrical shielding when using IC anodes (not covered in this paper)

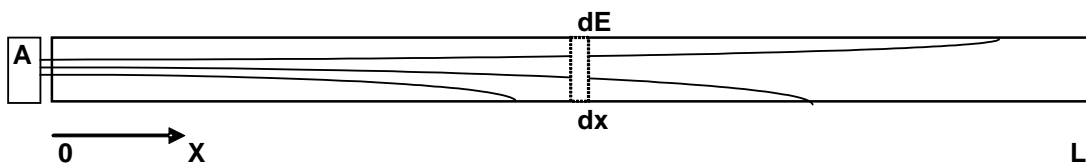
The different issues listed above have been evaluated and defined as Cases in the coming sections. Our BEM based CP modelling program, SeaCorr, have been used for all the modelling evaluation.

### 3 Cases

#### CASE I: Internal drain to piping/ibing

##### Calculation of protection length or drain to internal tubes using an analytical expression

For protection of internal of piping or drain to e.g. internal of top of piles, the current will flow from the anodes outside the pile. The situation is shown schematically in Figure 1.



**Figure 1** Schematics of internal cathodic protection of a pipe of length  $L$ , with the anode positioned at one end ( $x=0$ ) connected to the pipe.

Carbon steel protective potential range is from  $-800$  to  $-1050$  mV SCE with typical current densities in the range  $75$ - $100$  mA/m<sup>2</sup>. A well-known rule of thumb for internal cathodic protection of carbon steel pipes limits the protective length to 5 times the internal diameter (also defined in /1/).

Detailed mathematical relationships in order to calculate the potential profile inside the tube is presented and verified in reference /9/.

**The analytical expression.** If the current density is assumed to be independent of the potential, it may be shown that the following expression describing the total potential drop  $\Delta E$  in a tube of length  $L$  and diameter  $D$  is /9/:

$$\Delta E = \frac{\rho i L^2}{2D} \quad (1)$$

Here,

$\rho$  = seawater resistivity (Ohmm)  
 $L$ =Length (m)  
 $i$  = current density (mA/m<sup>2</sup>)  
 $D$  = diameter (m)

This equation may be rearranged to express the ratio  $L/D$ :

$$\frac{L}{D} = \sqrt{\frac{2\Delta E}{\rho i D}} \quad (2)$$

This equation shows that the ratio L/D is a function of both the current density and the tube diameter. In actual systems both of these parameters may show large variations. It is thus obvious that the ratio L/D may vary accordingly. To shed light on the expected variation in the L/D ratio calculations have been carried out for typical carbon steels tubes.

Calculations of current drain for internal piping of carbon steel: With carbon steel the protection potential is about –800 mV SCE while the anode potential is typically – 1050 mV SCE. This gives a maximum driving voltage of about 250 mV. In the potential range for protection the current density requirement for carbon steel is of the order 100 mA/m<sup>2</sup> or larger. Based on these parameters the results found in **Table 1** show that the ratio L/D varies from 14.4 to 1.9 when the tube diameter varies from 3 cm to 1.75 m. In table 2 to 5 different parameter combinations is evaluated.

<b>Carbon steel in ambient seawater</b>				5 * Diameter
dE	250	mV		
i	100	mA/m <sup>2</sup>		
roh	0.20	Ohm m		
Diameter (m)	Length (m)	Ratio L/D	Current (A)	Current (A)
0.03	0.43	14.4	0.0041	0,0014
0.05	0.56	11.2	0.0088	0,0039
0.10	0.79	7.9	0.0248	0,0157
0.25	1.25	5.0	0.0982	0,0982
0.50	1.77	3.5	0.2777	0,3927
0.75	2.17	2.9	0.5101	0,8836
1.00	2.50	2.5	0.7854	1,5708
1.25	2.80	2.2	1.0976	2,4544
1.50	3.06	2.0	1.4429	3,5343
1.75	3.31	1.9	1.8182	4,8106

**Table 1** Input parameters and L/D ratios calculated for carbon steel at resistivity 0.2 Ohm m.

Carbon steel in ambient seawater				5 * Diameter
dE	250	mV		
i	100	mA/m <sup>2</sup>		
roh	0.30	Ohm m		
Diameter (m)	Length (m)	Ratio L/D	Current (A)	Current (A)
0.03	0.35	11.8	0.0033	0,0014
0.05	0.46	9.1	0.0072	0,0039
0.10	0.65	6.5	0.0203	0,0157
0.25	1.02	4.1	0.0802	0,0982
0.50	1.44	2.9	0.2267	0,3927
0.75	1.77	2.4	0.4165	0,8836
1.00	2.04	2.0	0.6413	1,5708
1.25	2.28	1.8	0.8962	2,4544
1.50	2.50	1.7	1.1781	3,5343
1.75	2.70	1.5	1.4846	4,8106

**Table 2** Input parameters and L/D ratios calculated for carbon steel at resistivity 0.3 Ohm m.

Carbon steel in ambient seawater				5 * Diameter
dE	250	mV		
i	50	mA/m <sup>2</sup>		
roh	0.30	Ohm m		
Diameter (m)	Length (m)	Ratio L/D	Current (A)	Current (A)
0.03	0.50	16.7	0.0024	0,0007
0.05	0.65	12.9	0.0051	0,0020
0.10	0.91	9.1	0.0143	0,0079
0.25	1.44	5.8	0.0567	0,0491
0.50	2.04	4.1	0.1603	0,1963
0.75	2.50	3.3	0.2945	0,4418
1.00	2.89	2.9	0.4534	0,7854
1.25	3.23	2.6	0.6337	1,2272
1.50	3.54	2.4	0.8330	1,7671
1.75	3.82	2.2	1.0498	2,4053

**Table 3** Input parameters and L/D ratios calculated for carbon steel at 0.3 Ohmm and 50 mA/m<sup>2</sup>.

Carbon steel in ambient seawater				5 * Diameter
dE	400	mV		
i	50	mA/m <sup>2</sup>		
roh	0.30	Ohm m		
Diameter (m)	Length (m)	Ratio L/D	Current (A)	Current (A)
0.03	0.63	21.1	0.0030	0,0007
0.05	0.82	16.3	0.0064	0,0020
0.10	1.15	11.5	0.0181	0,0079
0.25	1.83	7.3	0.0717	0,0491
0.50	2.58	5.2	0.2028	0,1963
0.75	3.16	4.2	0.3725	0,4418
1.00	3.65	3.7	0.5736	0,7854
1.25	4.08	3.3	0.8016	1,2272
1.50	4.47	3.0	1.0537	1,7671
1.75	4.83	2.8	1.3278	2,4053

**Table 4** Input parameters and L/D ratios calculated for carbon steel with driving voltage 400 mV and 50 mA/m<sup>2</sup>.

Carbon steel in ambient seawater				5 * Diameter
dE	400	mV		
i	100	mA/m <sup>2</sup>		
roh	0.30	Ohm m		
Diameter (m)	Length (m)	Ratio L/D	Current (A)	Current (A)
0.03	0.45	14.9	0.0042	0,0014
0.05	0.58	11.5	0.0091	0,0039
0.10	0.82	8.2	0.0257	0,0157
0.25	1.29	5.2	0.1014	0,0982
0.50	1.83	3.7	0.2868	0,3927
0.75	2.24	3.0	0.5269	0,8836
1.00	2.58	2.6	0.8112	1,5708
1.25	2.89	2.3	1.1336	2,4544
1.50	3.16	2.1	1.4902	3,5343
1.75	3.42	2.0	1.8779	4,8106

**Table 5** Input parameters and L/D ratios calculated for carbon steel with 400 mV driving voltage and 100 mA/m<sup>2</sup>.

Based on the above equations (1) and (2), and as shown in tables 1 and 5, it is obvious that the rule-of-thumb of maximum  $L/D \cong 5$  is too conservative for pipe diameters above approximate 0.5 m. For diameters less than around 0.3 m, the drain is larger than the current for 5 times diameter, but the current for these diameter for is 100 mA or less.

### CASE protection of internal of caisson and chain connectors

For protection of chain connectors and caissons the pictures is much more complex. For the chain connector the bare chain inside the chain connector tube will significantly reduce cross section and at the same time introduce a large amount of

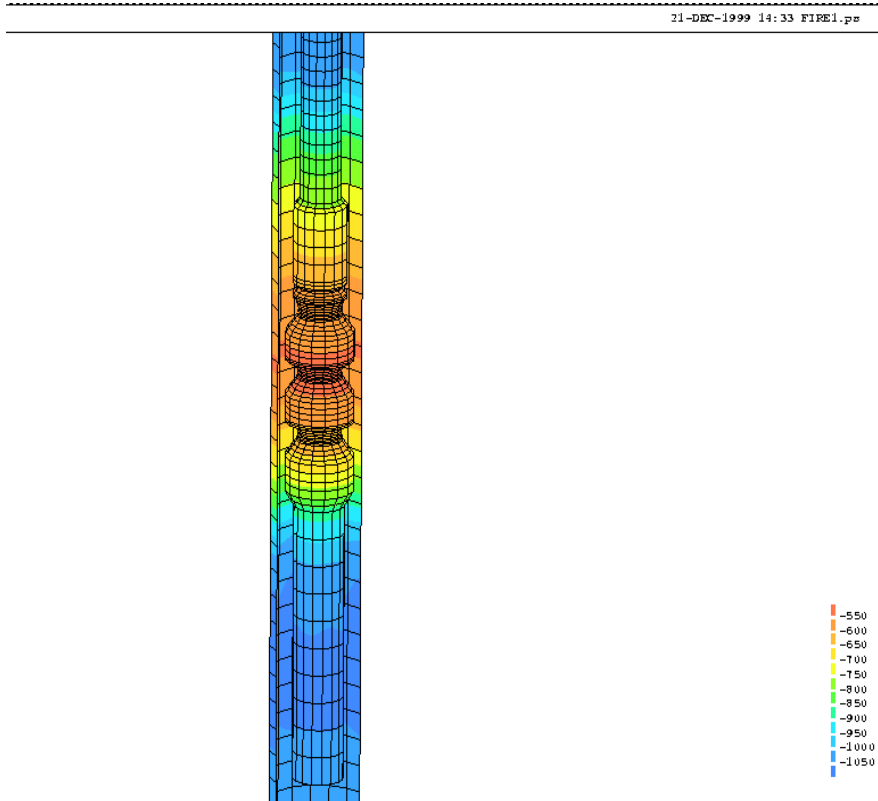
bare steel. For the caisson there is a corresponding problem with both e.g. pump riser, pump module, strainers, etc. inside the caisson. In order to evaluate and analyse the possibility to protect these component, this can be done by a modifications of equation (1) introducing the internal components as follows

$$\Delta E = \frac{\rho i L^2}{W} \tag{3}$$

Here,

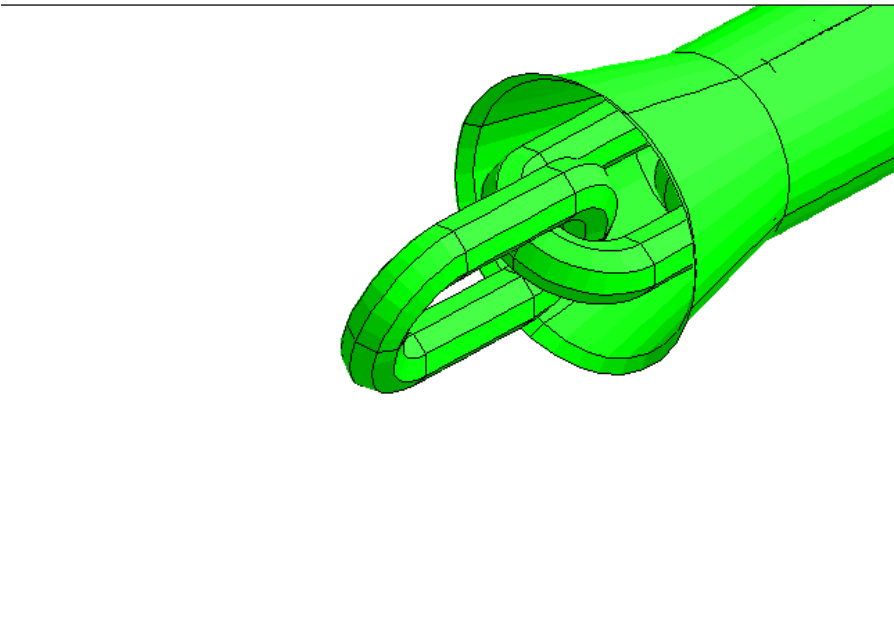
- $\Delta E$  = potential drop(mV)
- $\rho$  = seawater resistivity (Ohmm)
- $L$  = length of e.g. caisson
- $i$  = current density (mA/m<sup>2</sup>)
- $D$  = diameter (m)
- $W$  = (D<sub>o</sub>-D<sub>i</sub>)/2 (m)
- $D_o$  = inner diameter of outer pipe (m)
- $D_i$  = outer diameter of inner pipe (m)

Computer modelling (SEACORR) of pump caissons are presented in a previous paper (NACE 06105 /12/) and are found to be excellent tool for such problem where you need to account for both complex geometry both related anodes, steel variations in internal steel geometry

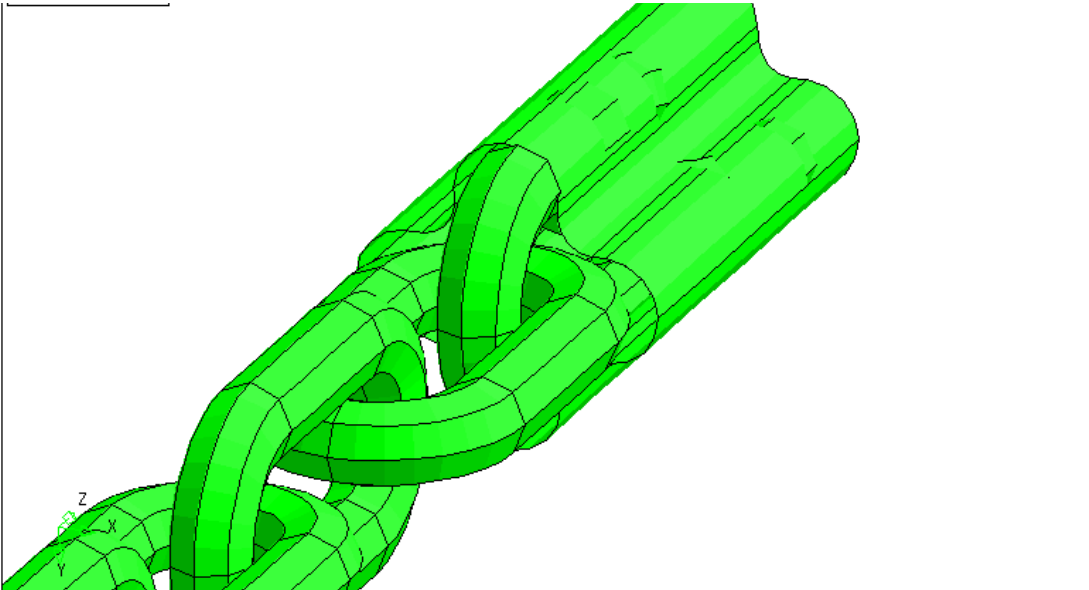


**Figure 2** Potential distribution inside a seawater caisson with pump riser, pumps and motor house

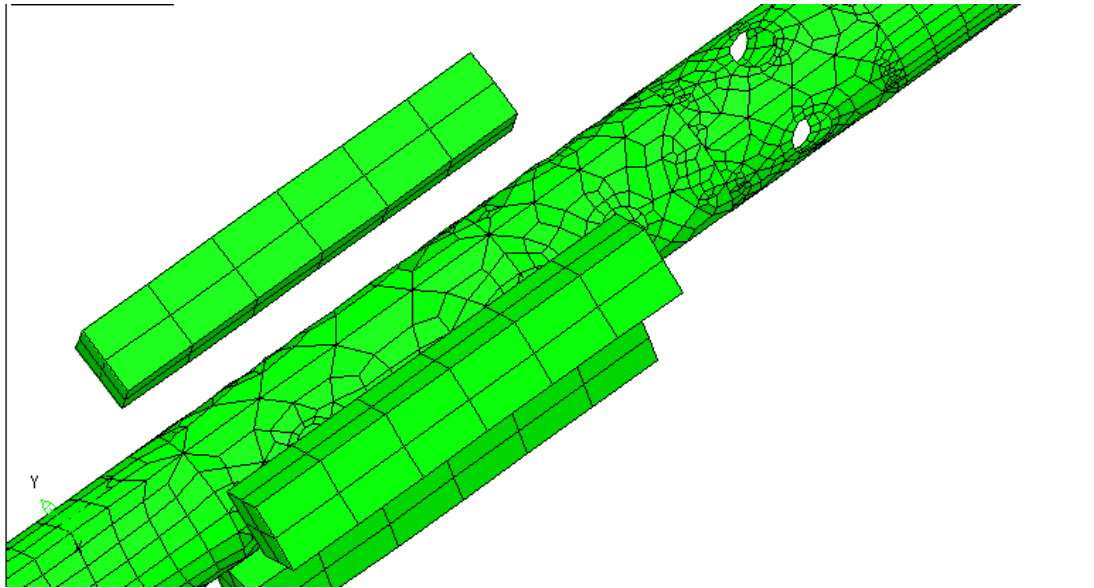
The complexity of the chain connector makes it difficult to through the simple equation to account for the complex geometry. CP modelling have been used to check the actual protection length



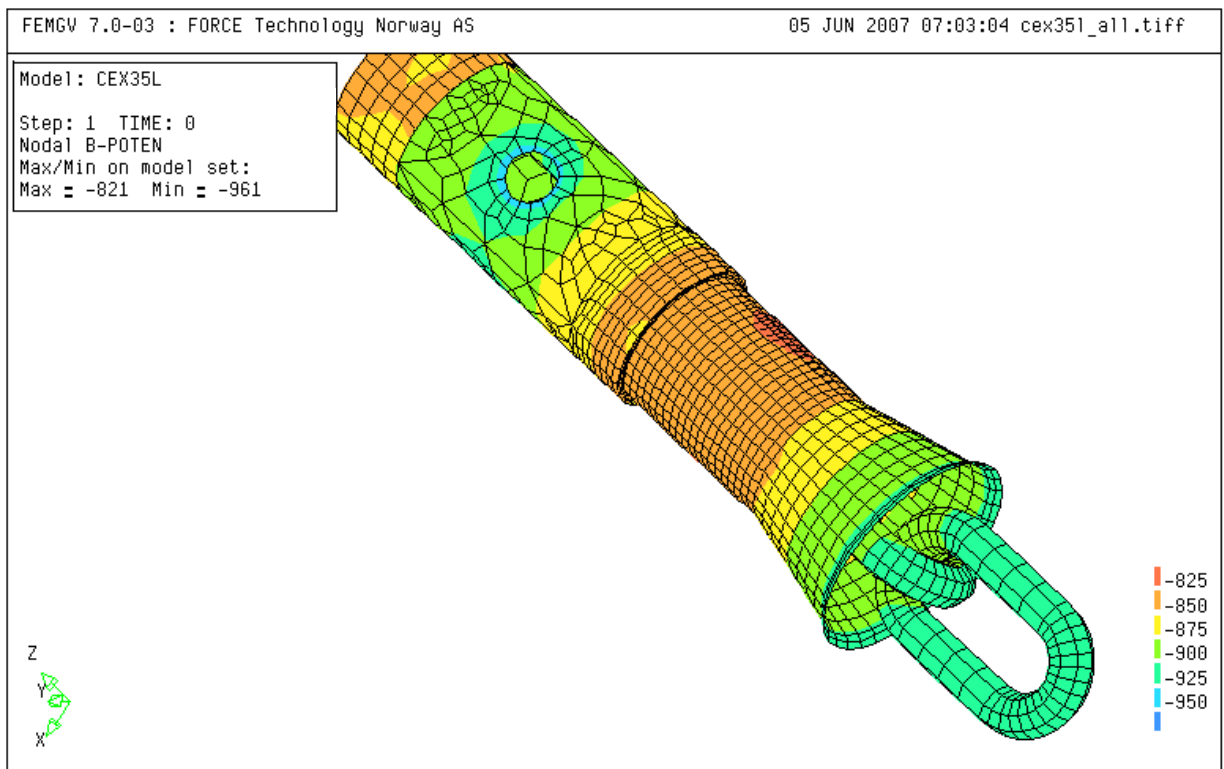
**Figure 3 Chain coming out of the chain connector**



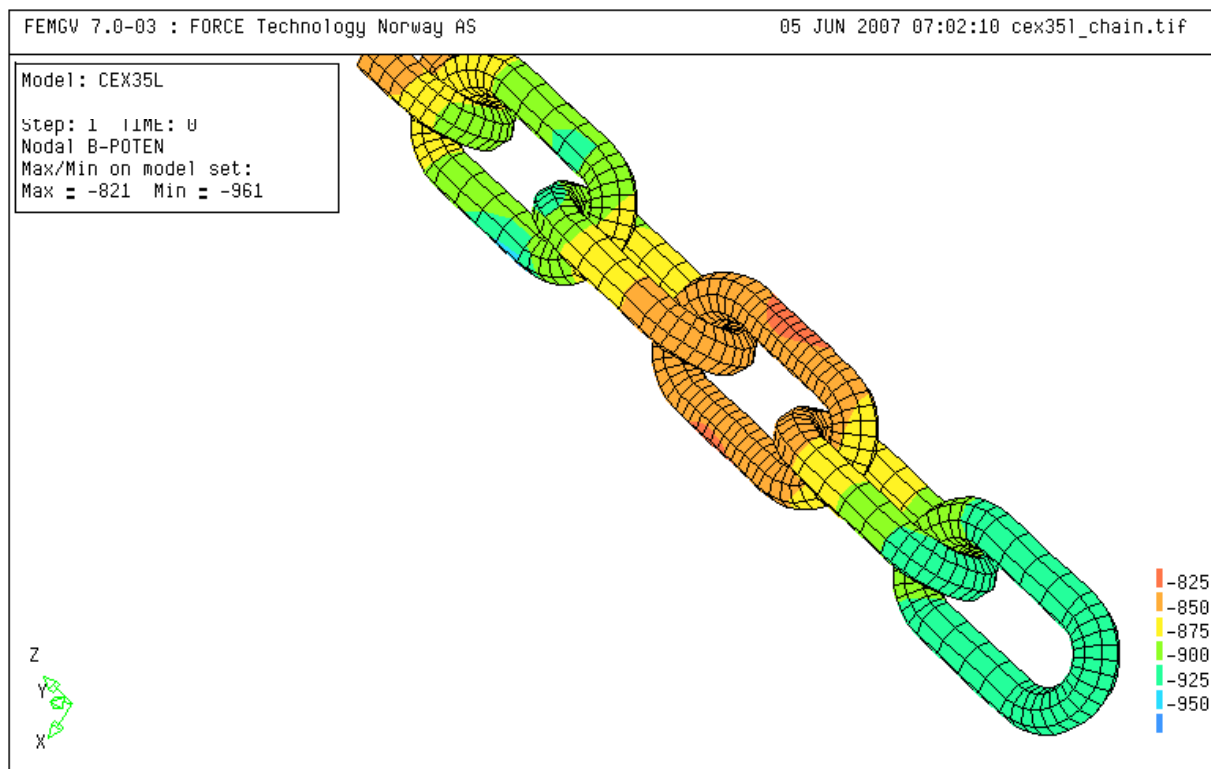
**Figure 4 Chain inside chain connector**



**Figure 5** Anodes on the outside of the chain connector. Holes for transporting protection in to the internal of the chain connector and chains.



**Figure 6** Potential distribution at the chain and internals of hawse and guide ring (seen from the outside)



**Figure 7 Potential distribution at the chain immediately outside the guide ring, inside the guide ring and inside the hawse**

Both examples above illustrate the importance of performing an evaluation of the internal potential drop in order to secure protection, where CP modelling have shown to be an effective and important tool. Introducing extra holes at optimal positions in the chain connector secured safe cathodic protection. Typical solution for the caisson problems is by redistribution of anodes and extra coating. The recommended practices do not include description of the need and necessity for such analyses.

### **CASE: ANODE interference**

Regarding anode interference, there is not much specific information found. From DnV RP B401 /1/, the following statement is found:

*” With the exception of very large anodes, shielding and interference effects become insignificant at a distance of about 0.5 meter or more. If anodes are suspected to interfere, a conservative approach may be to consider two adjacent anodes as one long anode, or as one wide anode, depending on their location in relation to each other.”*

This is not a very specific and clear guiding on how to avoid or account for anode interference.

In order to evaluate this in more detail, CP modeling by our SeaCorr (BEM based program) is performed to test different anode interference cases.

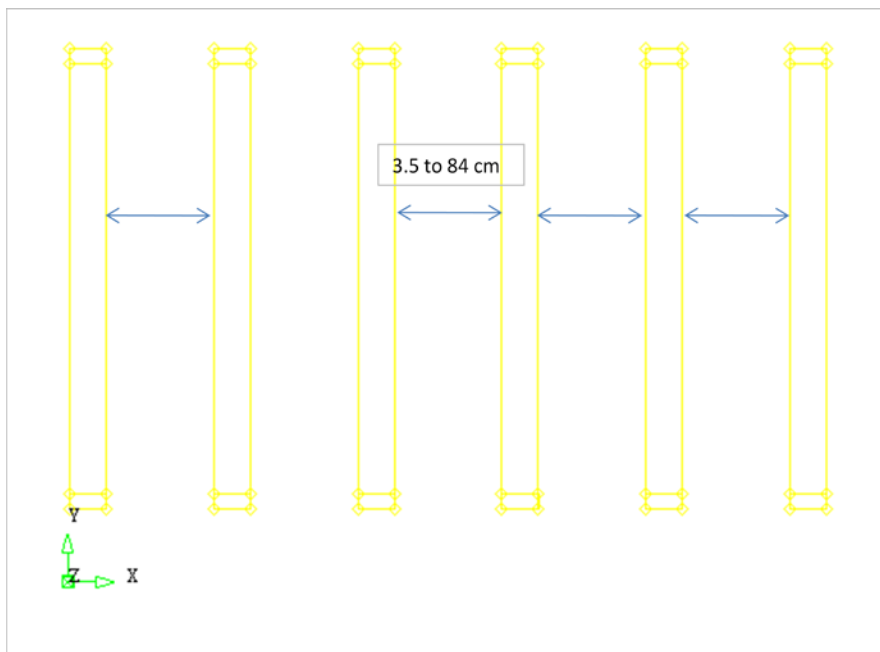
## Anode interference for stand-off anodes for remote protection

There are not found any recommendations for consequences for mounting a group of anodes relatively close to each other. This corresponds to use of anode sledges for long-range protection.

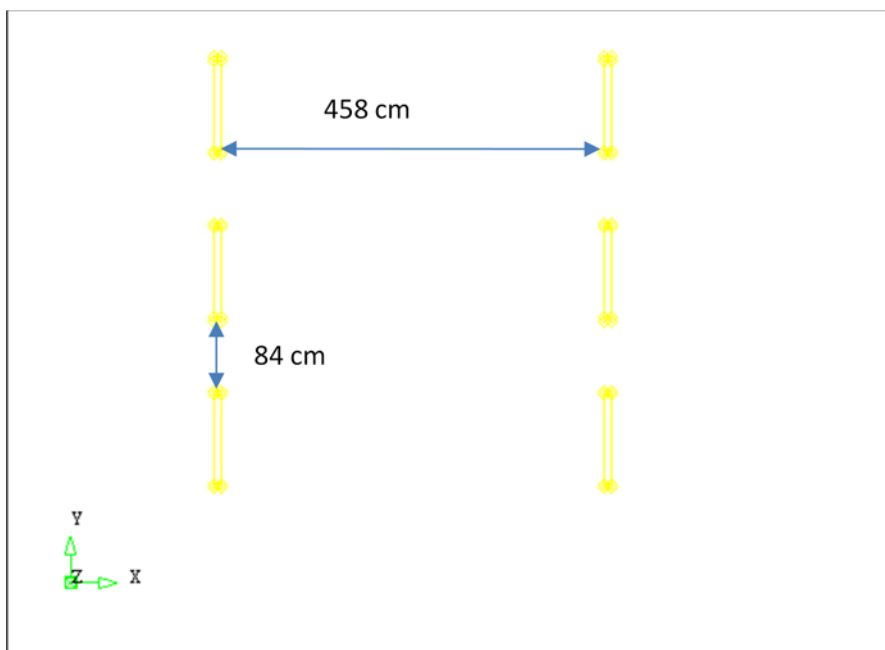
The anode dimensions and basis data are as follows:

Length:	112 cm
Height:	9.5 cm
Width :	9.5 cm
Stand-off:	30 cm
Resistivity:	0.3 Ohm m
Anode resistance:	0.1409 Ohm based on Dwight II
Number of anodes:	6
Net resistance 6 anodes:	0.0235 Ohm

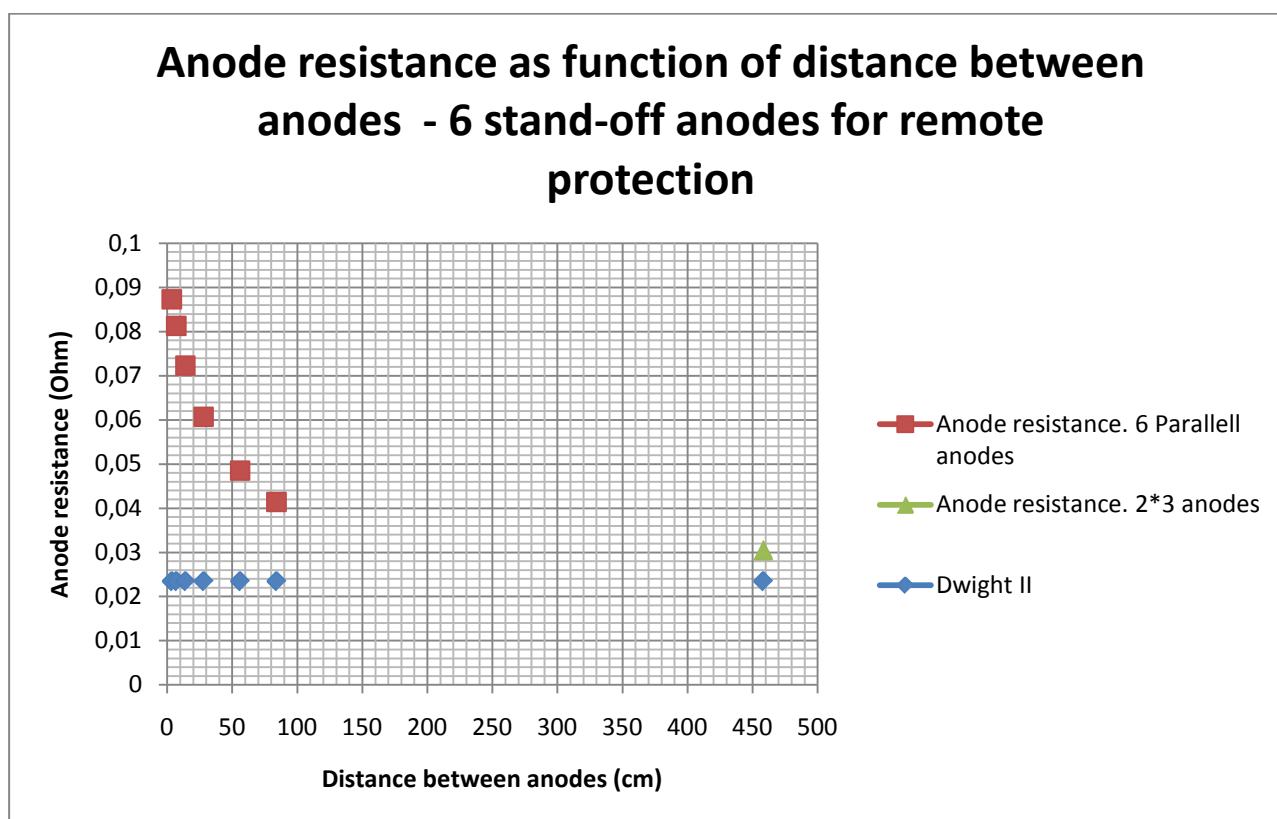
The models with dimensions are shown in Figure 8 and Figure 9



**Figure 8 Anode arrangement for 6 of the simulations**



**Figure 9** Anode arrangement for the 2\*3 anode simulations



**Figure 10** Net resistance for the anode group as a function of side by side anode to anode distance compared with the net resistance for the anode group (6 anodes).

The side by side distance between anodes do significantly increase anode resistance for the situation with anode arrangement installed for remote protection.

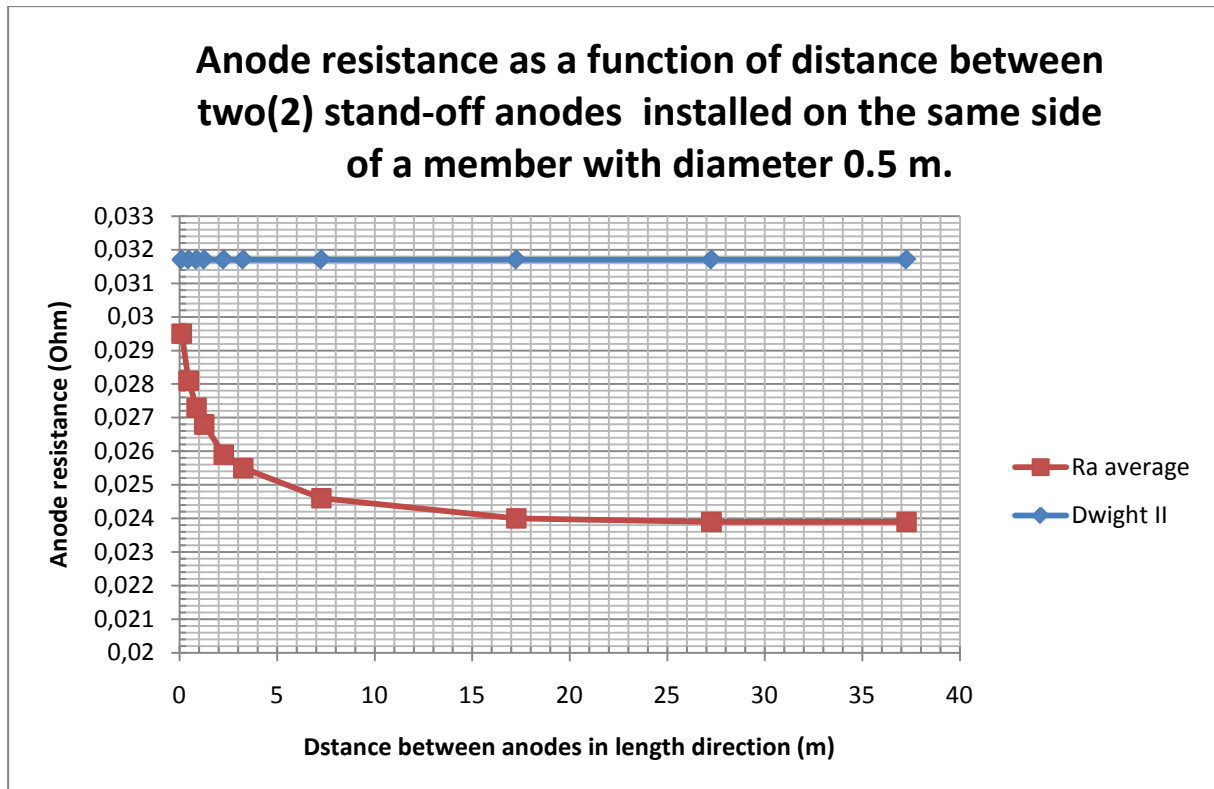
## **Anode interference for stand-off anodes mounted on a member for local protection**

This evaluation simulated several cases with different arrangement of anodes on a member with diameter of 0.5 m. The simulations are based on local protection of the member by the installed anodes. The evaluation includes the following main cases:

- Two anodes mounted on top of a member at different anode to anode distances
- Two anodes, one mounted on 6 o'clock and one in 12 o'clock position on a member at different anode to anode distances in length direction
- 2, 4, 8 and 12 anodes at one position around the circumference of the member
- 12 anodes distributes as follows:
  - 12 on top of member
  - 12 anodes equally distributed with one in 12 o'clock and the next n 6 o'clock position
  - 12 anodes distributed as 6 dual anodes (12 o'clock and 6 o'clock) equally spaced along the member

The anode dimensions and basis data are as follows are as follows:

Length:	262 cm
Height:	18.7 cm
Width top :	19.5 cm
With bottom	17.8 cm
Stand-off:	30 cm
Resistivity:	0.3 Ohm m
Anode resistance:	0.0634 Ohm based on Dwight II for one anode



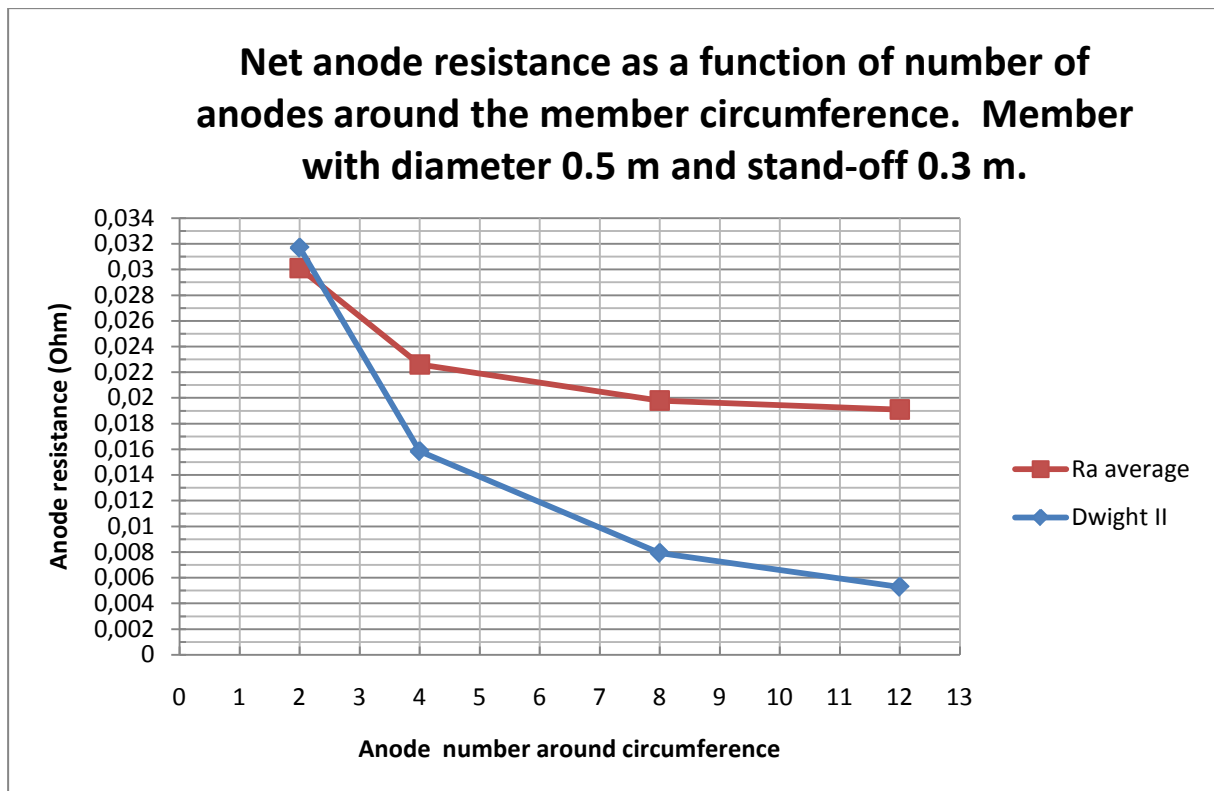
**Figure 11 Anode resistance of two anodes on same side of a member as a function of distance between the anodes in length direction**

The interference effect increases significantly as the anode to anode distance decreases:

- Around 3 m distance the increase in group resistance is factor 1.05
- Around 1 m distance the increase in group resistance is factor 1.1
- Around 0.05 m distance the increase in group resistance is factor 1.2

Despite these significant effect of anode interference the model resistance is less than the Dwight II group resistance.

In Figure 12 the results from evaluation of the anode interference for anodes mounted in a group around a member with from 2 to 12 anodes.



**Figure 12** Net anode resistance for anode around a member from two (2) to 12 anodes equally spaced around the circumference

The anode interference effect by installing anodes parallel around the member circumference is significant. As seen from Figure 12, anode interference effect for 12 anodes, and thereby loss of anode output capacity, is by a factor 3.6 compared to Dwight II resistance.

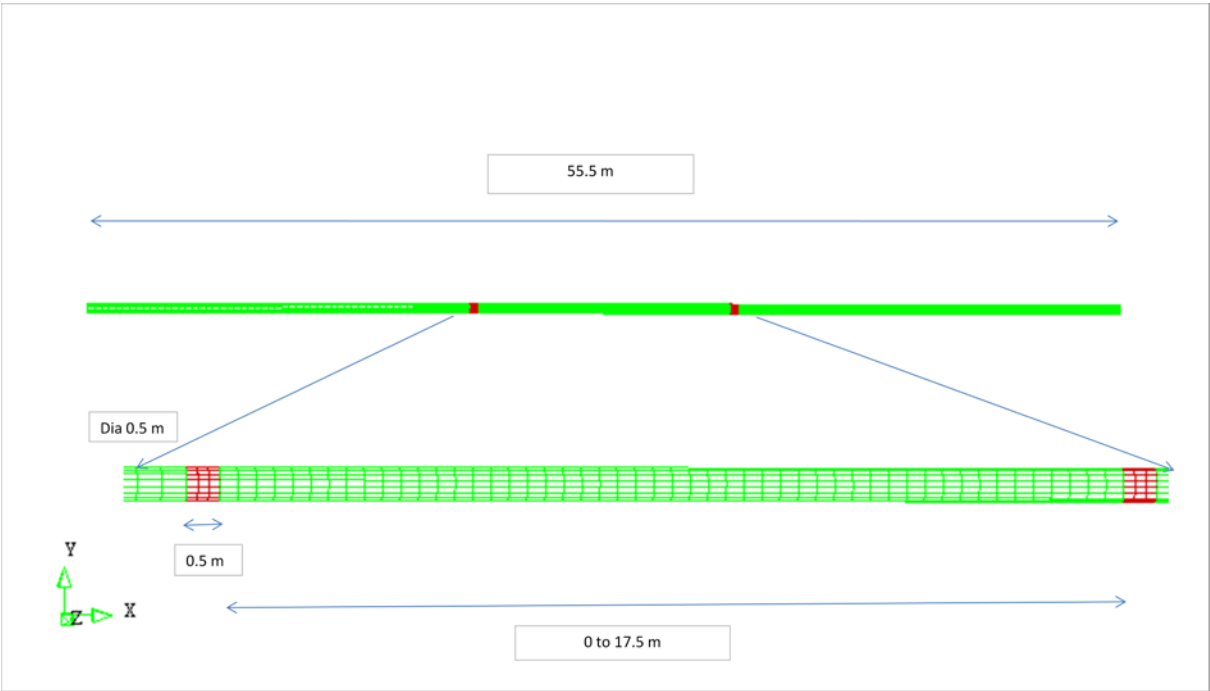
Distance between anodes along member (m)	Angle distance centre to centre (deg)	Anode arrangement	Stand-off (m)	Anodes #	Dwight II group resistance (Ohm)	Modeller group resistance (Ohm)
	30	12 anodes equally spaced around circumference	0.3	12	0.0053	0.0191
6.63		6 * dual (6 and 12 o'clock)	0.3	12	0.0053	0.0033
2.05		12 each second 6 and 12 o'clock	0.3	12	0.0053	0.0028
2.05		12 anodes all on one side	0.3	12	0.0053	0.0028

**Table 6** Net anode resistance for different anode grouping

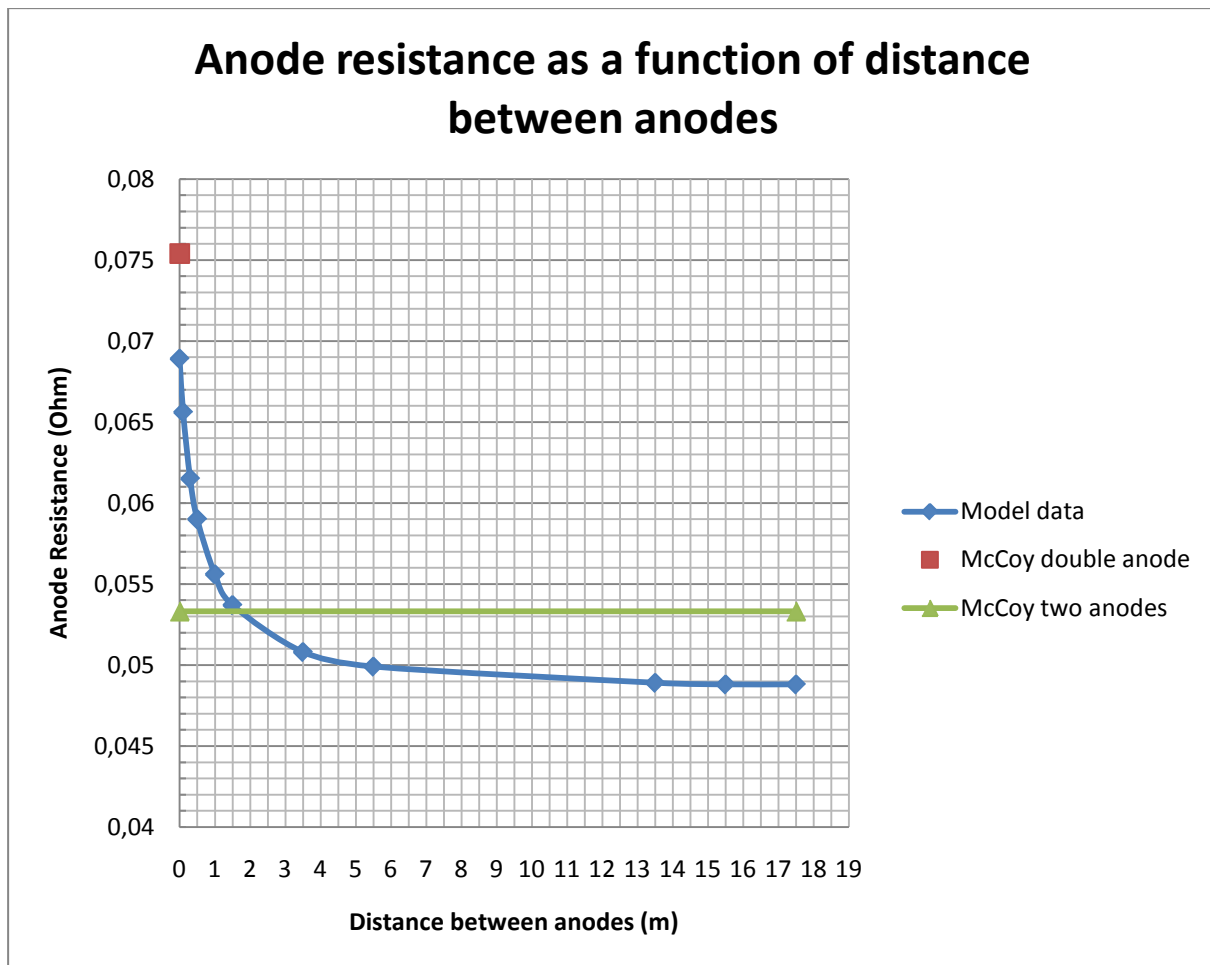
For both evaluated cases it is clearly seen that the distance in length direction of the anodes do influence the anode resistance less than the side by side distance (parallel anodes) which is not a surprising result.

**Bracelet anodes:**

CP modelling of a pipe section with two(bracelet) anodes are performed. The model and dimensions are presented in Figure 13 below.



**Figure 13 CP model of pipeline with two (2) bracelet anodes**



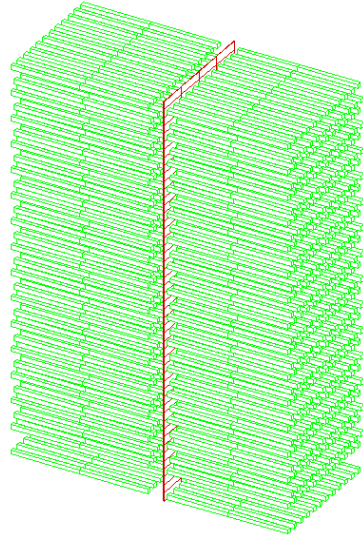
**Figure 14** Anode resistance of two bracelet anodes as a function of distance between anodes

For this anode dimension, the anode interference effect is readable for anode to anode distance less than 2 m, i.e. for shorter distances the anode group resistance will be larger than McCoy resistance.

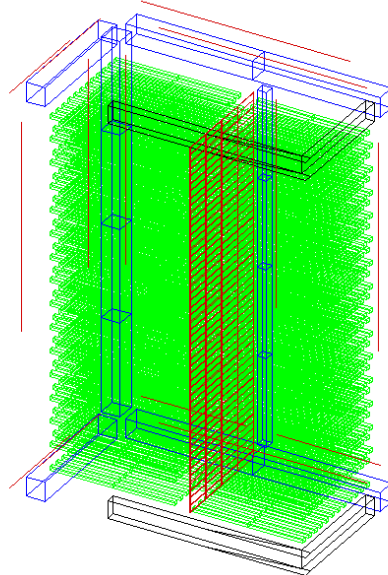
#### CASE: Shadow effects

There are several cases where “shadow” effects influences the CP performance. On a jacket there are conductors installed typical somewhere in the middle of the jacket and the sometimes there can be as many as 50. The anodes are typical installed around on the conductor guide frame and the jacket members itself. The conductors can be arranged as e.g. 6\* 8 conductors. In this case the conductors will cause a shadow for each other and the one in the middle will typical be less protected due to the additional shielding from the other conductors. This extra potential drop is not accounted for in the standard design rules.

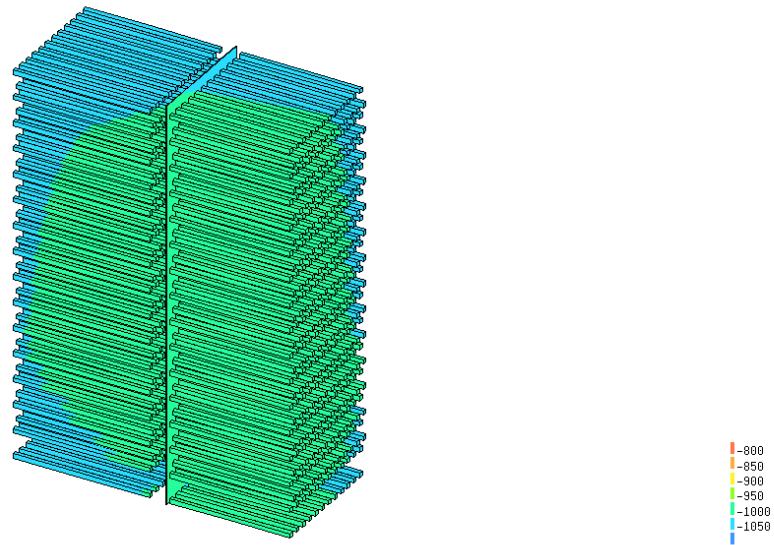
An example is a subsa cooler of super duplex of small bore tubing installed with a large density of tubes. The anodes are installed outside the tubing. The model geometry is shown in Figure 15 and Figure 16.



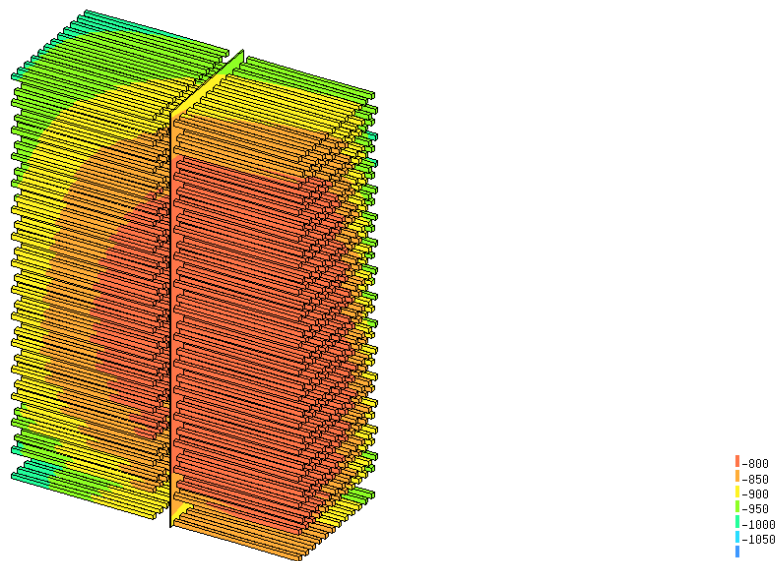
**Figure 15** Geometry of the model,  $\frac{1}{4}$  part of the actual structure. The tubing are green and the red area is the baffle plate.



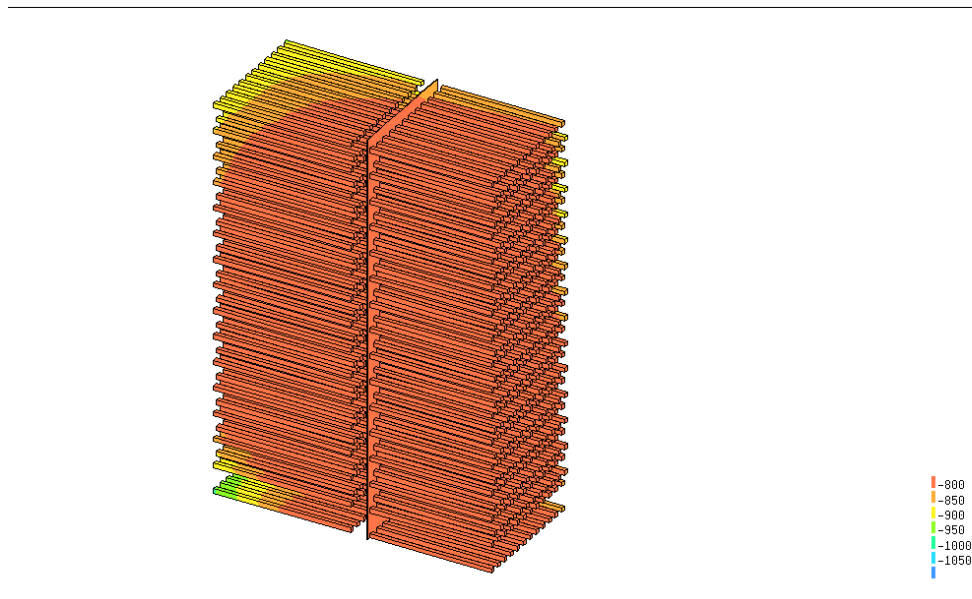
**Figure 16** Geometry of the model,  $\frac{1}{4}$  part of the actual; tubing (green), structure frame (blue), anodes (red), inlet/outlet (black) and baffle plate (red).



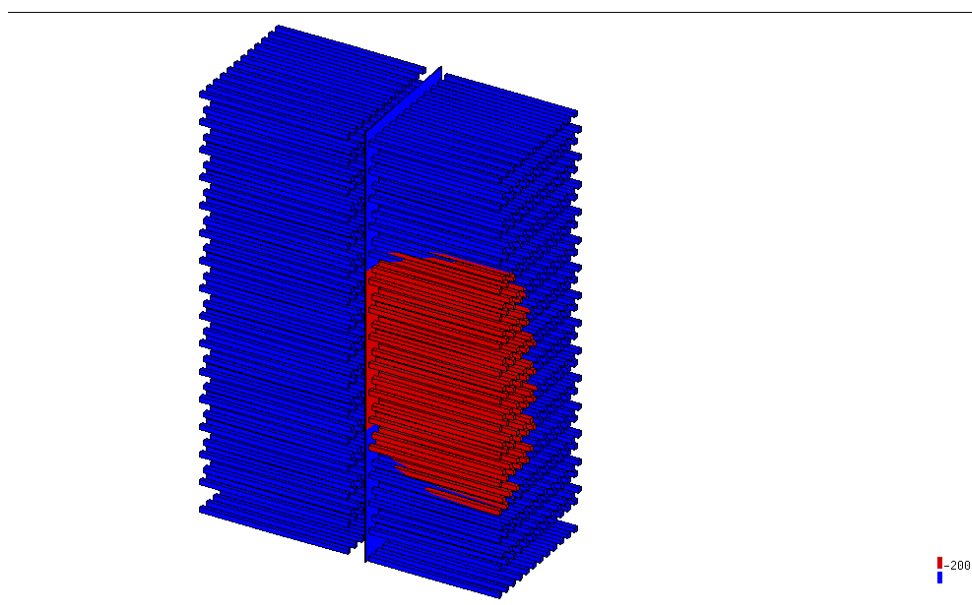
**Figure 17**  $\frac{1}{4}$  of the tubing, looking into the middle of tube arrangement. Initial situation with a coating system that is an average between coating system I and II.



**Figure 18**  $\frac{1}{4}$  of the tubing, looking into the middle of the cooler. Mean situation with a coating system that is an average between coating system I and II on the tubing.



**Figure 19** ¼ of the tubing, looking into the middle of the tube system. Final coating situation with a coating system that is an average between coating system I and II and mean current density on the tubing.



**Figure 20** ¼ of the tubing, looking into the middle of the tube system. Final situation with a coating system that is an average between coating system I and II at tubing. Potential cut at -200 mV, i.e. red areas are underprotected.

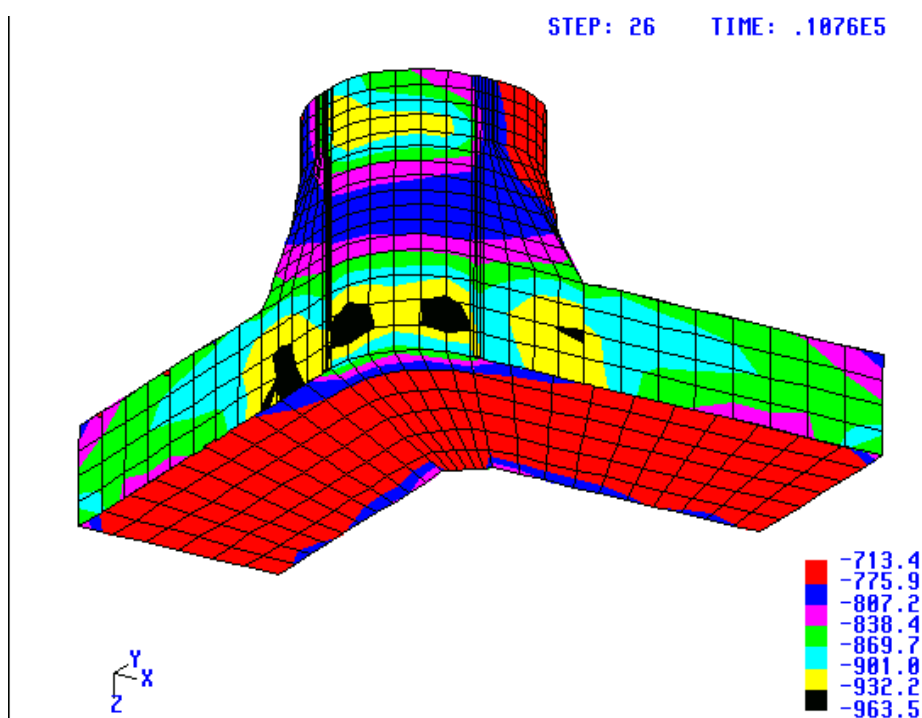
For this case it is clearly shown that CP calculation by standard design rules would not be able to secure protection, since the cathodic potential drop within the tubing is not defined in the Cp design recommended practices.

#### **CASE IV – Uneven anode distribution**

The design rules in the different guidelines are all based on the standard design calculation formulas which all are based on even distribution of anodes i.e. each single anode do provide equal “work”.

In most CP design there are limitations to where anodes are allowed to be mounted. Typical examples are floaters which requires barge transportation, which in worst case will result in that it is not possible to install any anodes at all on the flat bottom on the underside of the floater.

From previous paper /10/ the Åsgard floater is evaluated. There are no anodes on the floater underside and the required anodes where equally spaced on the remaining surface area. In Figure 21 the results in the last year of operation is shown and significant under protection where found. This is caused by the lack of anodes on the underside of the floater and that there are not distributed extra anodes along the floater sides to cover the bottom area. The anodes lowest down along the side will be consumed faster than other anodes and the distance to the middle of the bottom from the anodes is even longer.



**Figure 21 Potential distribution for TLP with no anodes underside of pantoon and column.**

In addition, the considerable current drain to the anchor chains will aggravate the uneven anode consumption rate and thereby increase this unfortunate effect.

In order to secure protection for these areas without anodes, more anodes have to be move to the areas towards the flat bottom and the chain area to account for the missing anodes and the extra current drain. CP modelling is an excellent tool to secure optimized anode distribution and protection or the entire life. For the specific case from paper /10/ the anode distribution was optimized and extra weight added to secure full protection for the entire operational life.

## CASE: Drain to well casings

Different data in the different recommended practices:

NACE /3/: 1,5 A to 5 A per well casings  
DnV /1/: 5 A per well  
NORSOK /2/: 5 A for per platform well and 8 A for subsea well

There is also performed CP modelling of drain to subsea well casings presented in NACE 1998 /11/. In Table 7 presents data from this evaluation.

ITEM	Current Drain to Well (Amp)		
	Initial	Mean	Final
<b>Njord</b>	8.5	5.8	<b>3.0</b>
<b>Visund</b>	10.8	<b>6.7</b>	3.8

**Table 7 Summary of current drain to a single well relevant for use in CP design**

The subsea wellhead templates are coated and therefore in the first years in operation there will be overcapacity and this opens for a relatively large drain to the well casings. As the coating breakdown increases the installed anode capacity is required locally on the structure reducing the drain to the well casings accordingly.

From the above data, drain to well casings should for purpose be at least 5 A. Actual measurements is recommended where possible, but further CP modelling will also give helpful data and understanding of the amount of current drain to well casings.

### Case: Current drain to steel in mud especially related to length of mud-exposed piles

There are not available any studies on the actual drain to piles in mud/sediment. The length of the piles varies significantly from around 10 m or less and up to 60 to 70 m. Typical design current density is (DnV /1/) 20 mA/m<sup>2</sup> and the drain current shall be calculated based on the full length of the piles. The current drain is naturally also dependent on the mud resistivity which can vary from 0.8 to 2 Ohm m. DnV /1/ recommends 1.5 Ohm m for anode resistance calculations installed in sediment.

NACE /3/: 1,5 A to 5 A per well casings  
DnV /1/: Include full length of pipe based of mud current density  
NORSOK /2/: Include full length of pipe based of mud current density

Based on a platform pile with a diameter of 1.17 m and a length of 60 m the current drain can be 4.4 A. The diameter for a windmill grounding pile can be 5 m which will result in a drain of approximate 19 A per pile, which is significant compared to the total requirements for a windmill!

There are performed some CP computer modelling of longer piles which may support that it is conservative to include CP drain to the full length. More work has to be done to establish a conclusion.

Actual measurements is also recommended where possible, but further CP modelling will also give helpful data and understanding of the amount of current drain to well casings.

### **Case Pipeline attenuation**

Remote protection of pipelines requires that there are performed attenuation calculations and/computer simulations. The attenuation calculations are necessary to check the actual possible protection length and accounts for the following:

- Pipeline metal resistance
- Anode resistance
- Remote seawater potential drop
- Coating breakdown
- Current density

In addition, the potential drop in seawater due to long-range current transport should be included in the total potential drop.

For long-range protection, the metal resistance and thereby the potential drop in the pipeline wall will be dominant.

DnV RP F103 /6/ have implemented a conservative, but simple formula and procedure for the attenuation calculation

The ISO standard /5/ main recommendation is based on Uhlig etc, but is also referring to the DnV RP F103 /6/ as an alternative approach.

None of the above methods accounts for the long range (remote) potential drop due to transportation in seawater. This potential is dependent the transportation length and the seawater cross section; i.e. if this is in shallow water the seawater potential drop can be larger.

## 4 Conclusions

From this evaluation, several issues are found not to be well covered or documented in the different design rules and recommendations. The three most important are the following:

1. Anode interference
2. Shadow effects, shielding and narrow space (e.g. large metal area compared to seawater volume), i.e. the cathodic potential drop is not included in standard calculations
3. Consequence of uneven anode distribution

CP computer modelling is the best solution to solve problems related to issue 2 and 3 and will secure an optimized CP design. For simpler cases, manual evaluation can be performed.

For issue number 1, anode interference, interference factors can be found by either measurements or CP modelling. These factors can be implemented in the CP design standards and recommendations.

From the evaluation of anode interference, the following main conclusions are found:

- Anode interference for stand-off anodes is most significant for short distance for parallel anodes
  - One example with anodes mounted parallel around the circumference of a member with diameter 0.5 m, the anode resistances are with:
    - 4 anodes gives a net resistance 1.4 times net Dwight II resistance
    - 4 anodes gives a net resistance 2.5 times net Dwight II resistance
    - 4 anodes gives a net resistance 3.6 times net Dwight II resistance
- Anode interference for anodes for remote protection (e.g. anode sledges) is larger than for anodes for local protection

The recommendation for drain to internal of open piles or other internal tubes (drain to 5 times diameter) needs to be refined. For diameters above around 0.5 m, the current drain estimate is conservative and the conservatism is increasing with increasing diameter.

In general CP computer modelling is found to be an excellent and necessary tool to analyse CP system and find solutions of the issues not covered in the CP standards and recommendations.

## 5 REFERENCES

1. Recommended Practice DNV-RP-B401 "Cathodic Protection Design",
2. NORSOK STANDARD M-503 "Cathodic Protection", Rev 3, 2007
3. NACE SP0176 (former RP0176) "Corrosion Control of Submerged Areas of Permanently Installed Steel Offshore Structures Associated with Petroleum Production"
4. EN12474 "Cathodic Protection of Submarine Pipelines"
5. ISO 15589-2 Petroleum and natural gas industries — Cathodic protection of pipeline transportation systems — Part 2: Offshore pipelines
6. Recommended Practice DNV-RP-F103 "Cathodic Protection of submarine Pipelines by Galvanic Anodes "
7. EN12495 "Cathodic Protection for fixed offshore structures"
8. Svenn Magne Wigen, Harald Osvoll, Per Olav Gartland and Weiji Huang: "Cathodic Protection of Stainless Steel", Paper no 07078 Corrosion 2007 Nashville, 2007
9. Svenn Magne Wigen and Harald Osvoll– FORCE Technology Norway AS "Efficient Cathodic Protection of Stainless Steel Heat Exchangers", Paper no. 1310 Eurocorr 2008
10. Frode Bjørnaas, Harald Osvoll, Per Olav Gartland; "New Aspects regarding Cathodic Protection of Floating Production Units", Nace 1999, Paper no 99359
11. Per Olav Gartland, Frode Bjørnaas "Computer modelling of Current Drain to Subsea Wells in the North Sea", Nace 1998, Paper no. 98555
12. Svenn Magne Wigen, Harald Osvoll, " Corrosion Problem in seawater pump caisson", Nace 2006, Paper no 06105
13. Harald Osvoll, Svenn Magne Wigen, Lene Marita Green, FORCE Technology Norway AS, "Mooring chains - extent of drain from ICCP system and sacrificial CP system", NACE 2009, Paper no 09066